



Integrated Distributed Energy Resources Overview

June 23, 2009

Comprehensive solutions to address challenges

Grid Efficiency

- Integration of Distributed Energy Resources (IDER)
- VAR Management/Support
- Technical Loss Management
- Grid Optimization

Reliability

- Asset monitoring and utilization
- Rapid fault location
- Substation automation
- Transformer monitoring

Resource Optimization

- Demand management for residential, C & I markets
- Renewable integration
- Direct load control
- Demand response

Grid Communications

- Network monitoring
- Network management
- Integration of multiple types of communication
- Distributed intelligence

BPL Global's Control Strategy

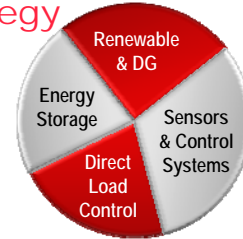

- BPLG creates monitoring & control interfaces to the edge of the electrical distribution grid.
- BPLG coordinates the capture, transport, archiving and interrelationship of data through pervasive networking.
- Solutions are enabled with the intelligence to analyze and model the data it has captured.
- The linkage harmonizes all aspects of energy delivery and consumption into a unified management system.

BPL Global Smart Grid Solutions



Substation Solutions
Extend asset life and improve reliability

Distributed Energy Resource Integration and Management
Integrate and optimize renewable sources of supply and storage

Load Management
Meet peak demand for ~1/3 the cost of new generation

Fault Location and Asset Protection
Identify and isolate faults to improve reliability

Power SG® - Integration and collaboration

Integrated Distributed Energy Resource (IDER)

Integrated Distributed Energy Resource (IDER)

Product Description

- **IDER coordinates capacity and load in order to meet reliability and efficiency requirements of the distribution system within defined areas. Areas can be as large as operating regions or as small as substations, circuits or individual customer premises. The IDER offering has been jointly developed with First Energy as well as other customer input.**

Value Proposition

- **Manage the energy delivery system based on the changing conditions of the grid, whether normal, emergency or critical**
- **Initiate granular, targeted load control to desired area / circuit to enhance operational reliability**
- **Integrate and fully manage distributed renewables and energy storage devices to shift peak demand, improve energy efficiency and reliability of distribution system**
- **BPLG's IDER application is the first of it's kind that fully integrates distributed supply, storage, and load as collaborative resources within a definable area**

Power SG Integrated DER - Status Indications

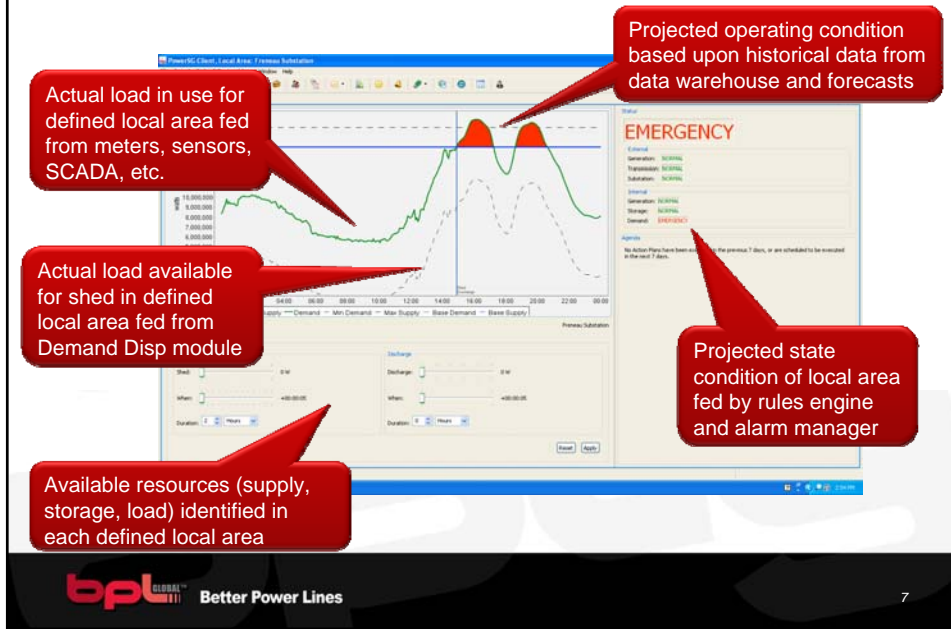

Power SG Integrated DER - Program Actions

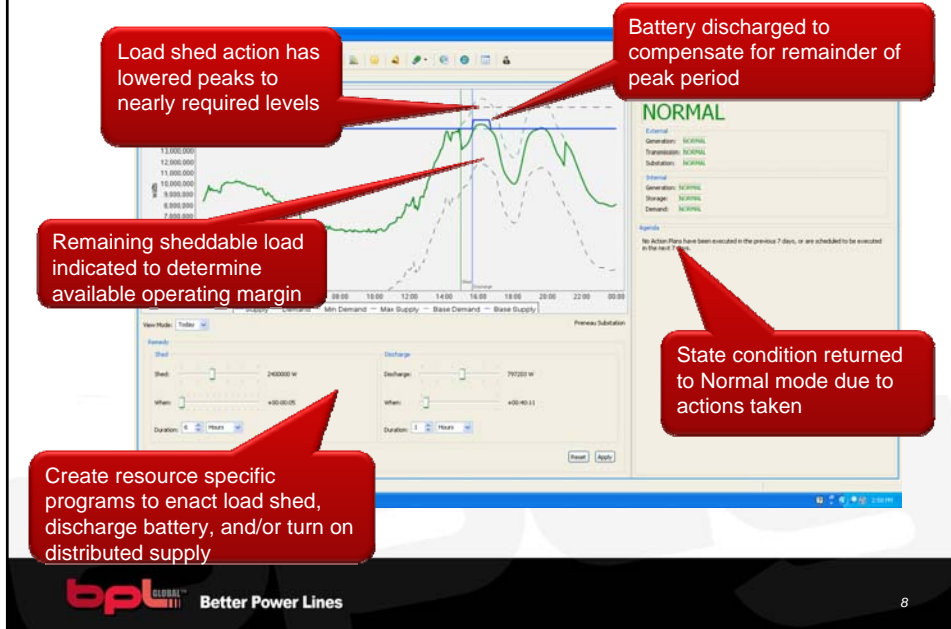

Integrated DER Direct Load Control Dashboard

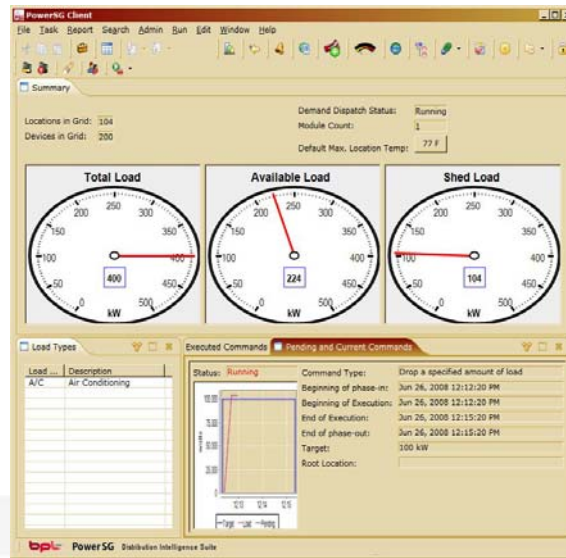

Advanced Storage Integration - Operational Examples

Hybrid DER Storage Configuration

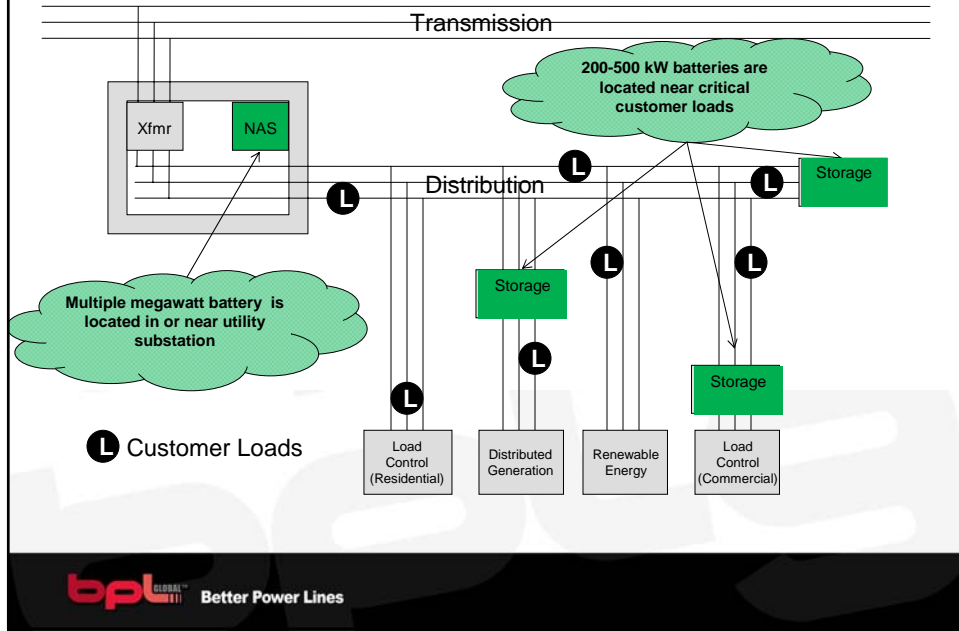

Hybrid DER Configuration - Normal Condition

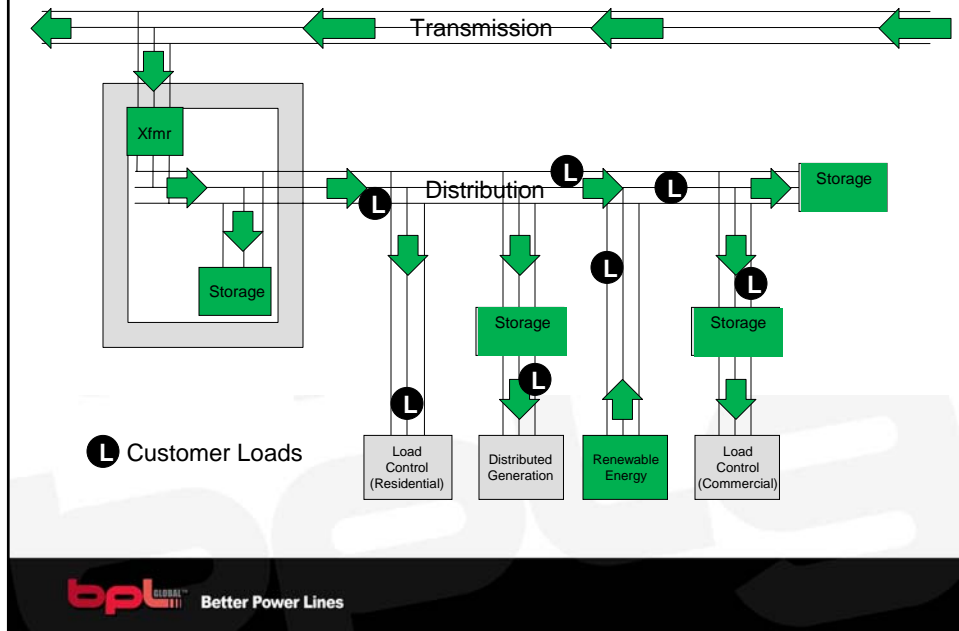

Hybrid DER Configuration - Stressed

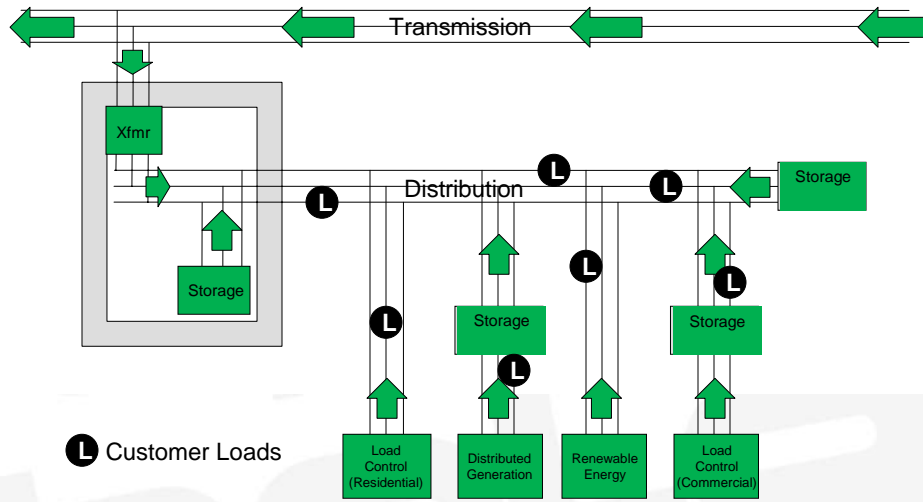

Hybrid DER Configuration - Emergency

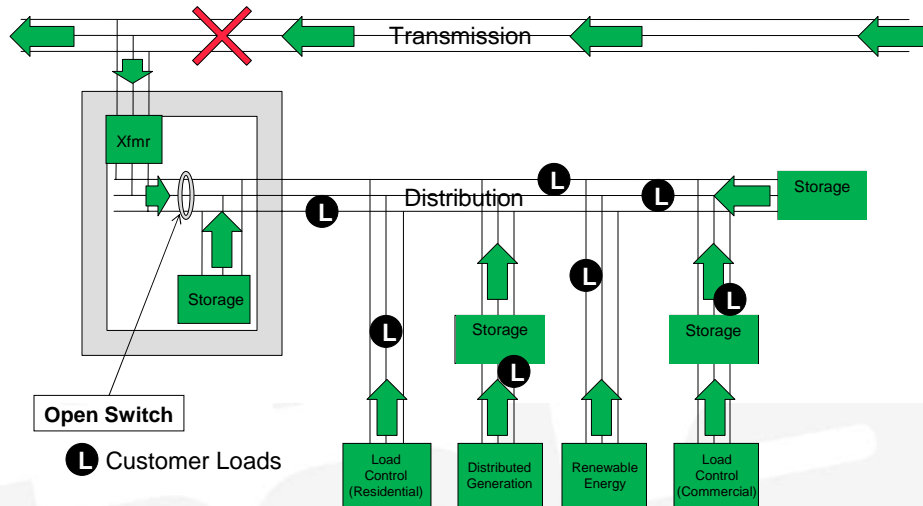

Residential Measurement and Control Diagram

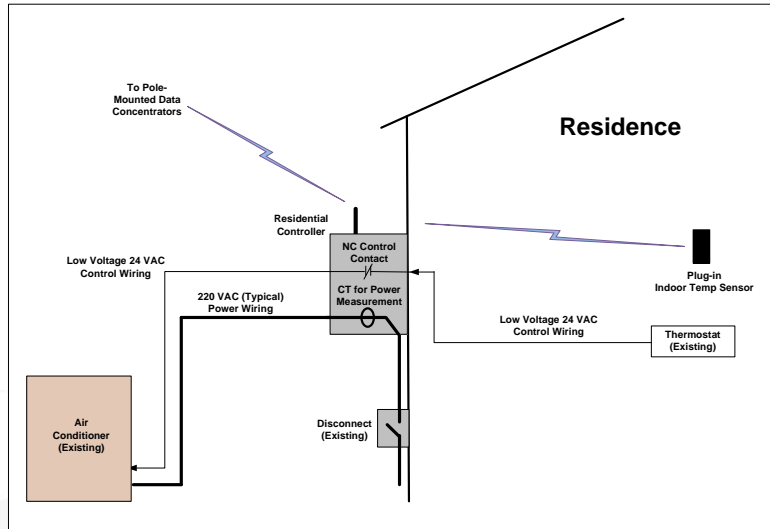

Two-Way Network Communications Diagram

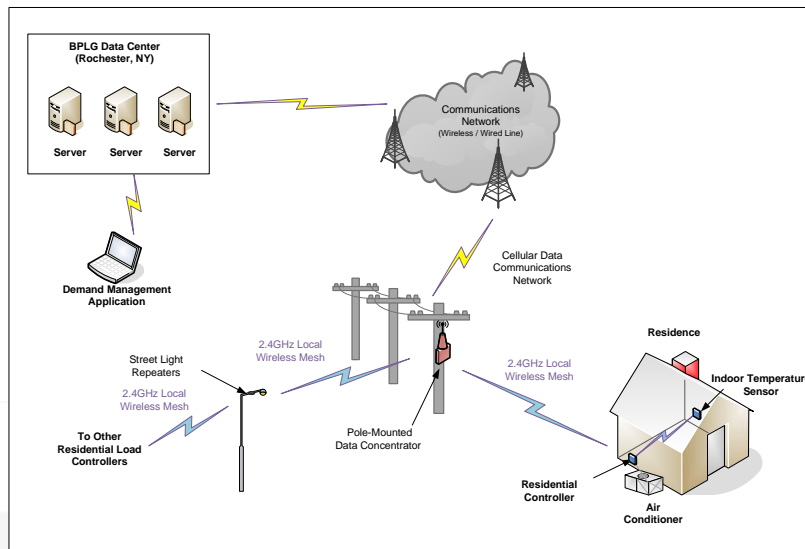

BPL Global Rapid Fault Locator (RFL)

Power SG® Rapid Fault Locator Process

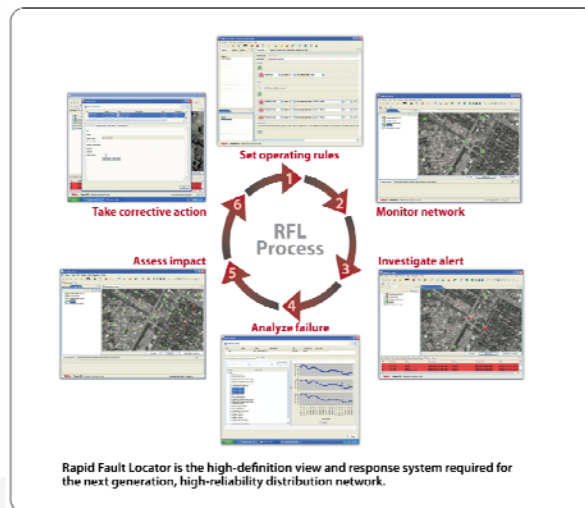

Typical RFL Deployment Example

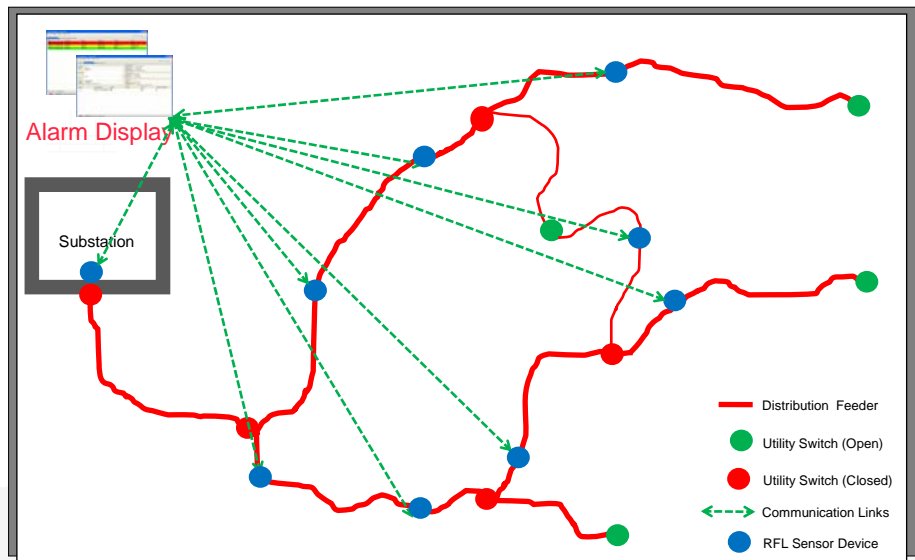

Power SG Rapid Fault Locator (RFL)

- Detects and reports line faults on overhead distribution feeders
- High sampling rates detects previously undetectable transients
- Geographical live view of the distribution grid status
- Flexible rules engine executes user-defined business rules
- Events can be captured and logged by rules observing patterns, exceptions or changes in the data.

Rapid Fault Locator Screen Shot

