

COMMUNICATIONS: The Smart Grid's Enabling Technology

INITIAL FINDINGS | NOVEMBER 15 2013



COMMUNICATIONS: The Smart Grid's Enabling Technology

INITIAL FINDINGS | NOVEMBER 15, 2013

Prepared by

Maurice Martin
Cooperative Research Network
National Rural Electric Cooperative Association
4301 Wilson Boulevard
Arlington, Virginia 22203-1860

and

Rick A. Schmidt
Power Systems Engineering
1532 W. Broadway
Madison, Wisconsin 53713

for

U.S. DOE/NETL
Morgantown Campus
3610 Collins Ferry Road
PO Box 880
Morgantown WV 26507-0880

The National Rural Electric Cooperative Association

NRECA is the national service organization for more than 900 not-for-profit rural electric cooperatives and public power districts providing retail electric service to more than 42 million consumers in 47 states and whose retail sales account for approximately 12 percent of total electricity sales in the United States.

NRECA's members include consumer-owned local distribution systems — the vast majority — and 66 generation and transmission (G&T) cooperatives that supply wholesale power to their distribution cooperative owner-members. Distribution and G&T cooperatives share an obligation to serve their members by providing safe, reliable and affordable electric service.

About CRN

NRECA's Cooperative Research Network™ (CRN) manages an extensive network of organizations and partners in order to conduct collaborative research for electric cooperatives. CRN is a catalyst for innovative and practical technology solutions for emerging industry issues by leading and facilitating collaborative research with co-ops, industry, universities, labs, and federal agencies.

CRN fosters and communicates technical advances and business improvements to help electric cooperatives control costs, increase productivity, and enhance service to their consumer-members. CRN products, services and technology surveillance address strategic issues in the areas:

- Cyber Security
- Consumer Energy Solutions
- Generation & Environment
- Grid Analytics
- Next Generation Networks
- Renewables
- Resiliency
- Smart Grid

CRN research is directed by member advisors drawn from the more than 900 private, not-for-profit, consumer-owned cooperatives who are members of NRECA.

Contact Information

National Rural Electric Cooperative Association
Cooperative Research Network™
4301 Wilson Boulevard
Arlington, VA 22203-1860
703.907.5500

Table of Contents

	Page
Foreword	ii
Section 1: Introduction	1
Section 2: Co-Op Case Studies	3
2.1 Adams Electric Cooperative (AEC).....	3
2.2 Clarke Electric Cooperative.....	4
2.3 Corn Belt Power Cooperative	5
2.4 Delaware County Electric Cooperative (DCEC)	6
2.5 Owen Electric Cooperative (OEC)	7
2.6 Washington-St. Tammany Electric Cooperative	8
Section 3: Defining Communications Requirements for Present and Future Applications .10	
3.1 Cooperative-Wide Automation and Communications Planning.....	10
3.1.1 Create a 10-Year Communications Plan.....	12
3.1.2 Create High-Level Requirements for each Application Requiring Communications	13
3.2 Key Communications Infrastructure Requirements.....	14
3.3 Typical Communications Infrastructure Requirements	17
3.4 How Much Throughput Is Needed?.....	20
3.4.1 Radio Frequency Bandwidth Data Rates: Vendor Quoted vs. Actual Installed .23	
3.5 Summary	23
Section 4: Future Work Needed On Telecommunications	25
4.1 Support from Regulators.....	25
4.2 Technical Innovation	25
4.3 Decision-Making Guidance	26

List of Figures

	Page
Figure 1. Creating a 10-Year Deployment Plan for Automation and Metering Applications	11
Figure 2. Communications Architecture within a Substation.....	19
Figure 3. Tower Site as Communications Mode	21
Figure 4. DA Points Feeding into Tower Sites and Substation DA Collection Nodes.....	22

List of Tables

	Page
Table 1. Typical Communications Infrastructure Requirements	17
Table 2. Benefits for Common Distribution Automation Programs.....	20
Table 3. Throughput Requirements for Common Applications	22

FOREWORD

The National Rural Electric Cooperative Association (NRECA) has organized the NRECA-U.S. Department of Energy (DOE) Smart Grid Demonstration Project (DE-OE0000222) to install and study a broad range of advanced Smart Grid technologies in a demonstration that involves 23 electric cooperatives in 11 states. For purposes of evaluation, the technologies deployed have been classified into three major sub-classes, each consisting of four technology types, the status of which have been reported in the Interim Technology Report of April 2013:

Enabling Technologies:	Advanced Metering Infrastructure Meter Data Management Systems Telecommunications Supervisory Control and Data Acquisition
Demand Response:	In-Home Displays & Web Portals Demand Response Over AMI Prepaid Metering Interactive Thermal Storage
Distribution Automation:	Renewables Integration Smart Feeder Switching Advanced Volt/VAR Control Conservation Voltage Reduction

To demonstrate the value of implementing the Smart Grid, NRECA has prepared a series of single-topic studies to evaluate the merits of project activities. The study designs have been developed jointly by NRECA and DOE. This document is the initial report on one of those topics, based upon the progress of the activity to date. The project team will be monitoring the progress of the various cooperative activities during the remaining term of the demonstration to close identified information gaps and identify additional information that will be of benefit to the merit evaluation. This document and the other single-topic studies then will be updated, as appropriate, for consideration in the final Technology Performance Report at the close of the Smart Grid Demonstration Project.

DISCLAIMER

The views as expressed in this publication do not necessarily reflect the views of the U.S. Department of Energy or the United States Government.

SECTION 1: INTRODUCTION

By Maurice Martin, NRECA

Studies conducted as part of the Smart Grid Demonstration Project have reaffirmed one truism: Communications are an indispensable enabling technology for any fully implemented Smart Grid. This becomes apparent when looking at a range of Smart Grid functions:

- ◆ *In-Home Displays/Web portals*. Communications are needed to bring most recent meter data back to the database that drives the Web portal.
- ◆ *Demand Response over Advanced Metering Infrastructure (AMI)*. Communications are needed to send demand response signals to meters and return measurements and verification of load reduction.
- ◆ *Prepaid Metering*. Communications are needed to collect usage data from meters and send connect/disconnect signals to meters and/or disconnect collars.
- ◆ *Interactive Thermal Storage*. Communications are needed to send control signals to water heaters and verify storage.
- ◆ *Smart Feeder Switching*. Switches need to communicate with each other and the head office to operate in a coordinated, effective manner.
- ◆ *Advanced Volt/VAR control*. Voltage regulators and VAR compensators need to communicate with each other and/or a control center to function in a coordinated, effective manner.
- ◆ *Conservation Voltage Reduction (CVR)*. Measurements of end-of-line voltages need to be communicated back to a control center.

Communication was identified as one of four enabling technologies for the demonstration, but it can easily be shown that the other three enabling technologies all are dependent on communications to some degree:

- ◆ *AMI*. More frequent meter reads require more bandwidth for transmittal to the meter data management (MDM) system.
- ◆ *MDM*. Requires more frequent meters reads (see above).
- ◆ *Supervisory Control and Data Acquisition (SCADA)*. Requires communication links between controlled devices (switches, etc.) and the control center, as well as between devices.

Communication thus plays a unique role in the Smart Grid—it is the enabling technology for other enabling technologies. Driving this demand for communications is the project that a fully implemented Smart Grid is likely to need, at an amount 10,000 to 100,000 times the data used by today’s current grid; also, much of these data will need to be moved from one point on the grid to another.

At the same time, it must be acknowledged that communication, in and of itself, does not directly provide value either to the utility, the end user, or society in general. The value provided by communication is indirect—it resides in the value of the Smart Grid functions that it enables, and only there.

This indirect value represents the first challenge to anyone wishing to estimate the value of a potential communication upgrade. The second challenge arises from the fact that a single communication system can support multiple Smart Grid functions. For instance, a single radio network may support both prepaid metering and demand response. Calculating the return on investment (ROI) of a communication upgrade requires knowing the value of each supported Smart Grid function, any of which may be uncertain.

In some cases, the communication upgrade may end up supporting functions that are implemented only later. Perhaps these functions would not even be considered until after the new communications are in place—the available bandwidth inspires system planners to consider functions that previously were unfeasible. For example, a utility that installs fiber to support smart feeder switching may find itself with excess bandwidth and later elect to use that bandwidth to support volt/VAR control. A utility with excess bandwidth is likely to look for ways to derive value from it.

The third challenge to estimating the value of a potential communication upgrade arises from the fact that communication technology itself is a moving target. This problem is familiar to everyone who buys consumer electronics. Is it better to upgrade a laptop today and immediately begin enjoying the latest technology? Or is it better to get another year of use out of an older laptop and upgrade in 12 months, when the new models will be cheaper, faster, and have more features? Utilities face a similar conundrum when considering a communication upgrade.

Finally, a fourth challenge arises from the fact that the Smart Grid functions supported by communications are also moving targets. Innovation in the utility sector is gaining speed—every day brings new ideas for reducing system losses, better integration of renewables, and improving reliability. Most of these new functions require bandwidth. But which of these emerging applications will survive the rigors of the marketplace, and how much bandwidth will they require?

Co-ops spend approximately \$38 million on demonstration activities, of which about \$2.5 million (about 6.6%) is spent on communication. This low number says almost nothing about the cost of communication needed to support Smart Grid functions, however—many co-ops did not upgrade their communications for the demonstration because they already had communications adequate for their planned demonstration study.

This spending amount says even less about how much communications would cost for a fully implemented smart grid—most co-ops that upgraded their communications for the Smart Grid Demonstration Project sized their new communications systems according to the immediate needs of their individual research projects. They did not ask “How do I begin building a communication system that will support all of my current and future Smart Grid needs?” Yet, this is the most important question that can be asked about communications at this time.

The answer will vary from utility to utility, depending on topography, grid configuration, environment, meter densities, and a number of other factors. What is needed is a guide to take utilities through the process of accessing their current and future communication needs and making sense of the myriad options available.

While such a guide is beyond the scope of the Smart Grid Demonstration Project, important insights can be gleaned from the co-ops that took part in the demonstration. Section 2 looks at the experiences of demonstration co-ops, with an emphasis on their decision-making processes and how these affected results.

Section 3 is a first attempt to define communication requirements for current and future smart grid applications. This attempt is presented with the caveat that more work is required in this area; this section does not provide a guide to decision making.

Section 4 identifies future work needed in the area of communications, including a guide to decision making.

SECTION 2: CO-OP CASE STUDIES

By Maurice Martin, NRECA

Co-ops that upgraded their communication systems as part of the Smart Grid Demonstration Project had a myriad of options to choose from, including microwave, spread spectrum radio, fiber optics, cellular, and leased telephone lines.

The processes they used to navigate through the many options and select a solution show how chaotic the communication landscape is at this time. Cost was obviously a major consideration, but other decision drivers included recommendations from other co-ops, desire to own (rather than lease) a communication system, familiarity with the manufacturer or system, compatibility with legacy equipment, and compatibility of the communication system with local topography.

Co-op experiences during the demonstration reinforce the need for extensive testing of communication equipment prior to final installation. In-place testing provides the most value, as some challenges only manifest themselves in the environment in which they will operate.

2.1 Adams Electric Cooperative (AEC)

Headquarters: Camp Point, Illinois

Number of meters: more than 8,500

Demonstration project requiring communications upgrade:

AEC’s goal was to improve reliability and restoration time for one of its key accounts: a Walmart complex. To this end, the co-op installed distribution automation (DA) switches (made by S&C Electric Company), which need to communicate with each other and the co-op control center.

Communications in place before the upgrade:

Adams already had MDS 9710 remote radios, which it used for AMI; SCADA data for its 13 substations; two DA switches; and a wind turbine. All locations have a line-of-sight antenna, with heights of 40–90 feet. There are two master radios at AEC’s main office—one for SCADA and the other for AMI. The other two radios are connected to their respective servers via fiber to serial converters with fiber links from the radio hut.

Communications upgrade(s):

- ◆ An additional MDS 9710 was installed to connect the new DA switches with the co-op control center.
- ◆ A new SpeedNet 900-MHz spread spectrum radio was installed to provide peer-to-peer communication between switches.

Criteria used in selection of equipment for communications upgrade:

- ◆ Cost
- ◆ Staff familiarity with the same or similar equipment
 - MDS 9710 was already in play; no staff training was required
- ◆ Compatibility
 - S&C made the switches being installed as well as the new SpeedNet Radio chosen to support them

Pre-installation testing:

- ◆ For MDS 9710, RSSI study
- ◆ For SpeedNet, line-of-sight study

Difficulties encountered during installation:

- ◆ For MDS 9710, units had beta version of firmware (intended for the factory only).
- ◆ For SpeedNet, a nearby Holiday Inn was emitting radio frequency interference (RFI), requiring the co-op to relocate the antenna designed to serve the Walmart complex. The relocation added 300 feet of coaxial cable and 12 hours of labor to the project.

Does the new communications technology meet the needs of the project for which it was purchased?

Yes.

Integration issues:

None reported.

Did the communications upgrade leave the co-op with excess capacity?

No.

Does the co-op anticipate further communications upgrades in the near future?

The MDS 9710 radios are no longer available; some of the older units are failing. AEC is replacing these with new MDS SD9 units.

2.2 Clarke Electric Cooperative

Headquarters: Osceola, Iowa

Number of meters: 5,000

Demonstration project requiring communications upgrade:

Clarke’s goal was to upgrade its automated meter reading (AMR) to AMI, add SCADA, add remote switching devices, and add load tracking capabilities through the regulators at the substation.

Communications in place before the upgrade:

Clarke used phone lines from the substations to the office. The cooperative had four different carriers, each of which had different pricing.

Communications upgrade(s):

- ◆ CalAmp Viper-SC 406.1-470MHz
- ◆ CalAmp Viper-SC Single Port Non-Redundant Base Station 406.1-470 MHz
- ◆ FreeWave HTP900-RE
- ◆ Cambium Networks Canopy Wireless PTP-300 5.8GHz

Criteria used in selection of equipment for communications upgrade:

- ◆ Cost
- ◆ Ownership
 - Desire to own communications infrastructure rather than depend on vendor (phone carrier)
- ◆ Recommendations from other utilities

Pre-installation testing:

RFIP performed field testing to determine communication type and height of poles and towers.

Difficulties encountered during installation:

Minimal.

Does the new communications technology meet the needs of the project for which it was purchased?

Yes.

Integration issues:

None.

Did the communications upgrade leave the co-op with excess capacity?

Yes. Clarke is considering uses for the excess, including additional automated switching and video monitoring at substations.

Does the co-op anticipate further communications upgrades in the near future?

No. However, this may change if Clarke decides to change AMI systems.

2.3 Corn Belt Power Cooperative

Headquarters: Humboldt, Iowa

A Generation & Transmission Cooperative

Demonstration project requiring communications upgrade:

Corn Belt’s goal in upgrading its communications system was to provide another channel to each distribution substation to support power line carrier communications on the distribution lines. This was for load management control as well as customer meter reading and monitoring.

Communications in place before the upgrade:

Corn Belt’s communications system consisted of a microwave backbone. Towers served as master sites for Multiple Address (MAS) radios, communicating with remote terminal units (RTUs) in the distribution substations.

Communications upgrade(s):

Corn Belt selected an MDS INET-II unlicensed radio from Larson Communications.

Criteria used in selection of equipment for communications upgrade:

Corn Belt had decided in advance that it would use Internet protocol (IP) communications to allow for other functions besides those that were part of the Smart Grid Demonstration Project. The co-op already had MDS I-NET equipment in place and wanted a seamless integration.

Pre-installation testing:

Several sites were checked using a basket truck to determine antenna height.

Difficulties encountered during installation:

Signal strength was an issue in places, requiring the installation of additional support structures to increase antenna heights.

Does the new communications technology meet the needs of the project for which it was purchased?

Yes.

Integration issues:

Minimal. Corn Belt had already updated its microwave backbone to include IP communications.

Did the communications upgrade leave the co-op with excess capacity?

The upgrade left Corn Belt with a small amount of excess capacity, which it uses to read substation meters. Corn Belt also lets its member distribution co-ops use this excess capacity to read customer meters.

Does the co-op anticipate further communications upgrades in the near future?

Corn Belt continuously upgrades its communication system.

2.4 Delaware County Electric Cooperative (DCEC)

Headquarters: Delhi, New York

Number of meters: 5,100

Demonstration project requiring communications upgrade:

Delaware County was upgrading to a new AMI system, which required IP communication circuits to all substations and purchase points to allow for full functionality.

Communications in place before the upgrade:

The AMR system at DCEC utilized dial-up (telephone line) circuits for communication receivers at the substations and purchase points. The SCADA system used for direct load control of customer water heating equipment used leased, analog, two-wire telephone circuits. Both systems used separate and distinct power line carrier technology from the substation or purchase points to the customer meter points or load control switch devices.

Communications upgrade(s):

For the upgraded AMI system, DCEC selected Landis+Gyr’s TS2 system (a power line carrier-based system).

For the upgraded SCADA system, DCEC upgraded its RTUs to the Survalent “Scout” model. (The SCADA master server, also provided by Survalent, had been upgraded during a previous project.)

For each substation or purchase point, IP circuits for backhaul were selected based on the availability specific to each. For instance, at one purchase point, DSL was installed by Margaretville Telephone Company. Verizon Wireless provisioned cellular telephone-based IP at two substations. Fiber optic-based IP service was provided by Delhi Telephone Company at another substation, and satellite-based IP was provided by Hughes Net at the remaining substation location.

Criteria used in selection of equipment for communications upgrade:

Data rate requirements were specified for the AMI and SCADA systems for their backhaul circuits. Based on these specifications, DCEC determined that the available IP circuits would be sufficient to implement the Smart Grid Demonstration Project upgrades.

Other factors:

- ◆ Topography—service area is mountainous.
- ◆ Low customer density.
- ◆ Staff familiarity with Power Line Carrier (PLC)-type equipment. DCEC has had a long-standing relationship with its AMR vendor.

Pre-installation testing:

DCEC conducted IP speed tests at one of two substation locations designated for cellular-based IP service to determine if the data rate performance and connectivity would be acceptable.

Difficulties encountered during installation:

Minimal.

Does the new communications technology meet the needs of the project for which it was purchased?

Project needs mostly have been met, aside from the occasional loss of connectivity of an IP circuit. DCEC has noticed that the AMI power line courier-based system has data rate limitations in certain selected modes of operation, such as the gathering and reporting of interval energy data and issuance of the load control commands. Also, DCEC has had issues with periodic drop-outs, due to low signal-to-noise ratios from certain areas of the PLC system. However, no critical factors were missed in the co-op’s original planning.

Integration issues:

For the AMI integration with the customer information system, few problems were noted. DCEC required significant assistance from both Landis+Gyr and Survalent to integrate the load management system with its AMI system. This assistance was in the form of software updates, setting changes, and command timing assistance.

The periodic drop-outs due to received low signal-to-noise ratios in certain areas of the PLC system have created problems for operation of the integrated outage management system (OMS). For conditions of low signal-to-noise ratio, the integrated OMS system will report outages on the system erroneously. The causes of the low signal-to-noise ratios appear to be related to the location of capacitive reactive compensation equipment, coupled with certain lengths of overhead line.

Did the communications upgrade leave the co-op with excess capacity?

The communications upgrade allows DCEC access to the Internet at all purchase points or substations, which may prove beneficial in the future.

Does the co-op anticipate further communications upgrades in the near future?

No other upgrades are planned in the near future.

2.5 Owen Electric Cooperative (OEC)

Headquarters: Owenton, Kentucky

Number of meters: 58,000

Demonstration project requiring communications upgrade:

OEC’s goal was to create a redundant loop for its backbone to have multiple routes for the wide area network (WAN) and be able to use the co-op’s Walton Service Center as an emergency relocation facility.

Communications in place before the upgrade:

OEC had a radial microwave backbone system combined with Telco Metro Ethernet to communicate between its headquarters and four other offices. It also used spread spectrum radios to communicate with substations.

Communications upgrade(s):

Fiber multiplexing (MUX) equipment was used for the optical ground wire (OPGW) fiber route because the fibers were being shared with East Kentucky Power Cooperative (EKPC), OEC’s G&T.

Criteria used in selection of equipment for communications upgrade:

- ◆ Future co-op needs. Existing bandwidth requirements were set as the base, with the communication needs of the other Smart Grid applications factored in.
- ◆ OEC also evaluated future needs in conjunction with its strategic plan and possible technologies that could be implemented to arrive at the final bandwidth requirements.

Pre-installation testing:

As part of the request for proposal (RFP), the microwave hop was required to meet both physical and software path study requirements before it was accepted. The MUX equipment was tested at EKPC on a test bench and required to be tested and installed on site by the vendor before being accepted.

Difficulties encountered during installation:

The microwave hop was a hot stand-by and there were some issues in properly setting up and connecting the backup units. The MUX equipment had issues on the T1 side with timing bits.

Does the new communications technology meet the needs of the project for which it was purchased?

Yes.

Integration issues:

Going from a radial WAN to a looped redundant environment created some complexities, and there were some temporary problems with the integration of Open Shortest Path First (OSPF) protocol.

Did the communications upgrade leave the co-op with excess capacity?

OEC anticipated having excess capacity after the upgrade, and this was indeed the case. OEC will evaluate bringing its Internet connection from another office to increase reliability and bandwidth while reducing cost. The co-op will also evaluate additional monitoring at its substations along the fiber route.

Does the co-op anticipate further communications upgrades in the near future?

OEC is considering increasing bandwidth at a number of other substations and looking at its future bandwidth needs for both distribution automation and AMI.

2.6 Washington-St. Tammany Electric Cooperative

Headquarters: Franklinton, Louisiana

Number of meters: 50,000

Demonstration project requiring communications upgrade:

Washington-St. Tammany’s goal was to make its transmission grid self-healing. To this end, the cooperative connected 24 transmission breakers to its SCADA system.

Communications in place before the upgrade:

Washington-St. Tammany had no communication to its substation prior to this project.

Communications upgrade(s):

The co-op is building out a 100+ mile fiber optic network to 18 of its substations, as well as a number of metering points. Prysmian 48F ADSS cable was selected, with Cooper Power Systems as the vendor. (Note: The co-op originally selected a microwave-based communications system. The reason for the switch to fiber is explained in the supplemental report “Washington-St. Tammany Case Study: Stress-Testing Designs Before Deployment.”)

Criteria used in selection of equipment for communications upgrade:

- ◆ Cost
- ◆ Industry standards
- ◆ Extra bandwidth (beyond what was needed for the SCADA system) for possible future applications

Pre-installation testing:

Washington-St. Tammany tested a single pair of fibers within the blue sleeve on the reels before installation. (Note: Testing done on the original microwave-based communications system directly resulted in a switch to a fiber-based system. For details, see the supplemental report “Washington-St. Tammany Case Study: Stress-Testing Designs Before Deployment.”)

Difficulties encountered during installation:

During the late 1960s and the early 1970s (the time during which the transmission lines were built), the designer did not foresee adding fiber. Most of the problems are occurring where the transmission line crosses the roadway and Washington-St. Tammany has distribution along the road. The fiber is installed below the intersecting distribution, yet must maintain 21 feet above the roadway. In many instances, Washington-St. Tammany has had to increase the transmission pole height by as much as 10 feet.

Does the new communication technology meet the needs of the project for which it was purchased?

Cannot be answered, as the fiber installation is still underway.

Integration issues:

Cannot be answered, as the fiber installation is still underway.

Did the communication upgrade leave the co-op with excess capacity?

The fiber installation, when completed, will leave Washington-St. Tammany with considerable excess capacity. The co-op is looking at different options to monetize this excess capacity. Options include leasing “dark fiber” and selling broadband to communities and consumers.

Does the co-op anticipate further communications upgrades in the near future?

No.

SECTION 3: DEFINING COMMUNICATIONS REQUIREMENTS FOR PRESENT AND FUTURE APPLICATIONS

By Rick A. Schmidt, Power Systems Engineering

Note: The Cooperative Research Network (CRN) is the national technology research organization managed by NRECA on behalf of its 900+ co-op members. When the Smart Grid Demonstration Project made it clear that defining communications requirements in this new era had grown far more complex, CRN commissioned Power Systems Engineering (PSE) to create the following guidance to support its efforts. Communications is undoubtedly a challenge throughout the industry. As a result, the following guidance may be of value to utilities outside of the co-op family. For this reason, CRN offers Section 3 of this report.

Of course, defining requirements is only a first step in addressing the communications challenge. Once the requirements are known, a guide will be needed to navigate the many options available. A plan for creating such a guide is discussed in Section 4.

Selecting the most appropriate communications architecture, technologies, and vendors starts with a roadmap that defines present and future communications requirements. Without clearly defined requirements, decisions could be made that are not the best choice in the long term. These short-sighted choices may be costly to rectify in the future.

This article presents a proven process for defining requirements and identifies typical requirements for the various segments of the communications architecture. The following topics are covered:

1. Detailed cooperative-wide automation and communications planning;
2. Key communications infrastructure requirements, such as latency, jitter, bytes per file/session, frequency of data being sent, interfaces, redundancy, level of mission criticality, security, and others; and
3. A review of the existing and emerging automation applications and common communications requirements for various applications, such as SCADA, Voice over Internet Protocol (VoIP), DA, mobile workforce, AMI, direct transfer trip schemes, and others.

3.1 Cooperative-Wide Automation and Communications Planning

In the past, adding a new application such as SCADA or AMI would drive the need to invest in new communications infrastructure; as new applications were added, co-ops would deploy a unique communications technology for each application. Because the technologies were less sophisticated and used primarily for single applications, the ramifications of a poor communications deployment choice, while disruptive to utility operations, would not usually spread beyond the realm of that one application.

Today, however, many co-ops are building more robust communications networks that can incrementally scale to the addition of new applications and enhanced capabilities of existing applications. Because most new communications infrastructure now supports multiple applications, and because that infrastructure is now more expensive, the risk of making the wrong choice is greater. To mitigate this risk, gaps in communications infrastructure should be identified prior to procurement by strategically planning for automation and communications across the utility over the next 10 years.

Figure 1 reviews the major steps involved in migrating from 10-year automation and communications plans through requirements definition.

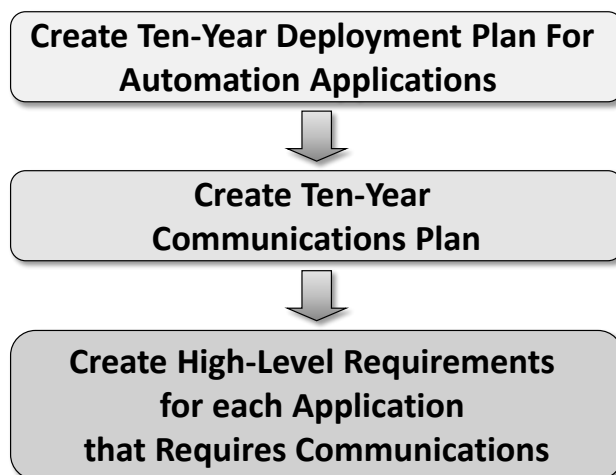

Figure 1. Creating a 10-Year Deployment Plan for Automation and Metering Applications

The 10-year deployment plan for automation applications is the key driver or influencer for communications. Although it is generally easier to forecast new automation programs with a three-year planning window, communications infrastructure has a life of 10 years or longer, so it is important that the cooperative extend its plan accordingly.

Listed below are factors that co-ops may want to consider when creating a 10-year deployment plan for automation applications:

- 1. Existing Reliability Situation:** How much improvement is desired for electric reliability? Knowing where the co-op stands regarding Customer Average Interruption Duration Index (CAIDI), System Average Interruption Duration Index (SAIDI), etc. compared with its peers is a good start in identifying areas that may need improvement. Applications such as DA, new forms of SCADA, and even new types of outage restoration processes may all require new communications infrastructure. Therefore, a co-op could forecast the timing of programs such as DA or SCADA over a 10-year planning window.
- 2. SCADA Changes at the Substations:** If a co-op does not have SCADA now, or if changes possibly could be made to the SCADA master (such as migrating from a proprietary protocol to Distributed Network Protocol/Internet Protocol (DNP/IP) within the 10-year planning window, new communications at the substations could be required.
- 3. Office Communications Links:** Many co-ops have district offices, but those offices are often connected via data links to the main office, where systems such as the Customer Information System (CIS), AMI, OMS, and the phone system are housed. These data links often are undersized. This situation can be further exacerbated by the implementation of self-run cloud technologies (or “private clouds,” as they sometimes are called). Therefore, forecasting the bandwidth requirements for various offices needs to be part of the 10-year plan.
- 4. Impact of Cloud Computing:** A growing number of software applications are now available through vendors that offer cloud-based software solutions. “Cloud-based” generally refers to “Public Cloud” software run in a central data center off site from the co-op and accessed via the public Internet. Now that we are seeing cloud-based versions of software such as Meter Data Management Systems (MDMS) and other Software-as-a-

Service (SaaS) applications, the Internet is becoming much more mission-critical than in the past. Given these developments, we are now seeing co-ops increasing the bandwidth for the links that connect to the Internet, and often adding a redundant communications link to enable a second connection. A cooperative should forecast the impact of cloud computing on its automation programs over the next 10 years.

5. **Existing Automated Metering Situation:** If no AMI is in place now, or the co-op has at least a 10-year old PLC-based AMR system, there is a strong probability that within 10 years a new type of AMI system could be needed. This requirement may trigger the need for new backhaul communications.
6. **Possible Changes from Demand Side Management (DSM) Programs:** One-way 150 MHz paging and PLC technology historically has been used for load control. However, co-ops are now looking at a variety of technologies for transporting DSM. Therefore, a long-range forecast for DSM could impact long-range communications needs.
7. **Changes in the availability of the current service:** In some cases, a provider will decide to discontinue a service. For example, AT&T recently discontinued offering its frame relay service, leaving Georgia Transmission Corporation to hunt for alternatives. It is important to talk with service providers to find out their future plans for services.
8. **Increased role of telecommunication companies in providing communications services to utilities:** Co-ops are advised to engage telephone companies and wireless commercial providers to find out what services they offer now and what services they plan to offer in coming years. Recently, Prairie Power from Jacksonville, Illinois worked out an agreement with a cooperative-based telephone company to provide fiber optics for the backbone and members’ electric substations.
9. **Mobile Radio Plans:** Co-ops should consider what changes may be required for mobile radio communications in the future, as in some cases their needs are shifting to IP base backhaul versus circuit switched. Digital trunking Land Mobile Radio (LMR) product lines are now generally affordable for co-ops needing to address mobile voice needs.
10. **Mobile Data and Automated Vehicle Location (AVL):** Co-ops should consider what communications requirements may be needed for mobile data or AVL in the next 10 years. The software for mobile service orders, mobile outages orders, and service order scheduling has greatly improved, and devices such as iPads and smart phones also have improved.
11. **Security requirements of future communications infrastructure:** With the sophistication of cyber-attacks increasing, and technology advances working against existing security mechanisms, attention must be paid to communications security (data-in-transit security). Even if the communications device does not have built-in security mechanisms, various encryption mechanisms, such as SSL, certificates, and virtual private networks (VPNs), can be leveraged to secure the data on these links. Periodic risk assessment, vulnerability assessment, and security planning need to be included in the overall planning with regard to communications.

3.1.1 Create a 10-Year Communications Plan

A 10-year communications plan can include communications for existing programs, such as those described above, and any other existing applications that require communications infrastructure. The more challenging programs to forecast, however, are new programs not currently in place at a co-op.

It is important to make decisions on the following:

- 1. What current and new Smart Grid applications will be supported over the decade.**
New programs may hard to predict, but it is worth the effort to engage all stakeholders and get their perspectives on what will be in place at different points over the next 10 years.
- 2. The schedule of program deployment as well as the associated number of sites and costs for those deployments on an annual basis.** Many co-ops create annual budgets based on planning for that 12-month period only, but a 10-year plan ensures that utilities are budgeting with an eye toward the future.
- 3. Internal consensus on the level of mission criticality for each new program from a reliability standpoint.** For example, a program may be defined as (a) mission critical and having a high impact on members, (b) operation critical, or (c) neither mission nor operation critical. These decisions could influence the subsequent decisions regarding what type of assets require either redundancy or some type of ring topology to protect against communications failures.
- 4. Defined preference between private and commercial communications technologies per application.** Most utilities prefer the use of private communications technologies over commercial technologies for mission-critical applications. However, the often higher costs of private communications, the occasional lack of spectrum or higher cost of spectrum and, in some cases, a shortage of in-house communications expertise, can result in some use of commercial technologies.
- 5. Shared LMR system and public safety.** There are a few states in which G&T and distribution co-ops have partnered with public safety organizations and received Federal Communications Commission (FCC) waivers to share an LMR system with public safety. First Responder Network Authority (FirstNet), an independent authority within the National Telecommunications and Information Administration (NTIA) intended to provide emergency responders (including utilities) with the first high-speed, nationwide network dedicated to public safety, is a new opportunity that is in its initial stages; it shows the potential for sharing a fixed data technology with public safety organizations. State-level meetings are just beginning on this topic; the rules and structure are in the early stages of development. For information on the progress of FirstNet, visit: www.ntia.doc.gov/category/firstnet.
- 6. Defined preference between outsourcing to fill any existing staff gaps versus using existing or future internal staff.**
- 7. Identification of any existing communication assets that can be leveraged over the long term, such as tower sites, fiber or microwave, relationships with local communications providers, and the communications experience of existing staff.**
- 8. Defined internal willingness to share a communications link with a variety of applications, such as mixing AMI and SCADA over the same link.**

Once the applications that require communications are identified, the deployment time frame is identified, and decisions are made for the types of questions listed above, the 10-year communications plan can be documented. The next step is to define requirements.

3.1.2 Create High-Level Requirements for each Application Requiring Communications

The remaining sub-sections discuss some of the areas for which requirements must be defined, such as bandwidth and reliability, that apply to most applications and corresponding communications media. Individual vendor products are not discussed—rather, the focus is on defining requirements during the communications planning stage, with the goal of influencing

the design of the communications architecture. Defining requirements during the planning stage enables cooperatives to make technology-level decisions before procurement so that their procurement will be smoother and more focused, saving them (and vendors) time and money.

For example, to determine a technology connecting substations to the main office, a co-op should begin by defining the high-level requirements for throughput, latency, interfaces, etc. Then the co-op determines what technology best meets those requirements. It might evaluate fiber optics, point-to-point microwave (licensed or unlicensed), point-to-multipoint spread spectrum, VSAT satellite, telco data leases, cable TV leases, WiMax point-to-multipoint, or private mesh-based products. Once a technology is selected, the cooperative can identify the appropriate vendors. When the co-op has refined its requirements and detailed specifications for procurement, it can issue an RFP only to those vendors.

3.2 Key Communications Infrastructure Requirements

There may be any number of requirements associated with a particular application, but the importance of those requirements will vary, depending on the utility’s needs. In developing communications requirements, the utility should consider what is most important in each of the following areas:

- 1. Operational Rules by Application:** Identify any “operational rules” associated with future applications that will be relying on the communications infrastructure. For example, if the utility is planning to migrate Ethernet connectivity to the substations, will the SCADA data acquisition thus change from polling to an unsolicited report by exception? Will AMI data be acquired at the master more often, such as going from once a week to once a day, four times a day, 24 times a day, or every 15 minutes? How many seconds of latency are acceptable from when the data are sent to when they are delivered? Will district office Internet traffic be routed over a link to the main office and then connected to the Internet from the main office, or will it connect to the Internet directly from each district office? All of these types of operational decisions will impact the requirements developed for the RFP.
- 2. Deployment Timeline by Application:** We have already discussed the importance of a 10-year plan on an annual basis. Incorporating all applications planned for the lifetime of the backhaul network (about 10 years) helps a utility to understand the impact of its technology selection further into the future. For example, the co-op might weigh the option of deploying a more robust backhaul technology now than what actually is required for the initial technology deployment (such as AMI, for example) to accommodate future scalability for DA or other planned applications.
- 3. Data Throughput and Latency:** Throughput is defined as the amount of data that must be transmitted, and at what rate, to meet a latency requirement. Throughput is measured in bits per second, such as: “kbps,” which is kilobits per second, or “Mbps,” which is megabits per second. Latency is defined as how much time it takes for a packet of data to get from one designated point to another. It sometimes is measured as the time required for a packet to be returned to its sender. It must be determined how much delay can be tolerated in the transmission to meet a defined user or system need. Sometimes the term “round-trip latency” is used to define the time it takes in seconds or milliseconds (ms) for data to travel from the master to a device and back to the master—such as how long it takes to travel from the SCADA master to a voltage regulator to retrieve a voltage read and return that information to the SCADA master. Various applications and programs have different latency expectations.

4. **Frequency of Data Transfers:** This refers to how often the communications facility is planned to be used. For example, a Wi-Fi access point located at a substation might not be used every day, or it might be used as often as several times per day. Depending on need, a video camera located at a substation that is currently programmed to send a network health check once every half hour could be reprogrammed to send a video feed only when an “event” occurs or when requested by a dispatch employee. Therefore, that asset could sit idle most of the time. By contrast, SCADA might be programmed to send a data file once every five seconds around the clock.
5. **Interface – Serial or Ethernet:** Most new applications are interfaced with Ethernet to provide wider availability to communication products, more flexibility for maintenance of the communications site, and greater bandwidth. It is expected that many applications will remain serial for several years to come, but the clear trend is to migrate to Ethernet in the future.
6. **Reliability or Availability – 99.9%, 99.99%, or 99.999%:** Reliability or “availability” is defined as the probability that a system will perform without a failure for a stated period of time. Often these percentages are used fairly loosely and mean different things to different people. However, there are standard software programs and testing procedures available to determine the level of reliability achieved at, for example, a given microwave link. The distance of the link, the size or gain of the dishes, coax type and length used, throughput delivered, precipitation, and other factors all contribute to reliability. Sometimes these reliability percentages are used as targets, such as backbone at 99.999% (about 5 minutes per year of downtime), substations at 99.99% (a little less than an hour per year of downtime), or feeder devices such as cap banks or fault indicators at 99.9% (about 9 hours per year of downtime).
7. **Battery and/or Generator Backup:** Does the cooperative’s communications system require generator backup? Does the application need to be available during a power outage? Generally, for SCADA and DA applications, the co-op probably wants to have the ability to monitor and control during power outages. AMI systems, on the other hand, do not need to have generator or battery backup, as meter readings do not change if there is no power flowing to them. The co-op also may want some systems to have battery backup, so that it knows if an outage is caused by a communications network failure or some other failure.
8. **Licensed vs. Unlicensed for Wireless Communications:** With the use of licensed technology, the designer must understand frequency border rules and avoid self-interference. Gathering information from co-users and other licensed spectrum users in the area is often completed in the requirements and pre-design phase of the project. With the use of unlicensed technology, part of the requirements-gathering process involves understanding the number of other unlicensed users that possibly share the same tower or are using the same unlicensed spectrum within the same path planned for the use of the application to be deployed.
9. **Ring Topology vs. Network Diversity or Secondary Link:** Backbone networks are often built with a ring topology, such that if a given communications link breaks between two points, a second route exists between them, thus avoiding an outage. Often this second route is a different type of back-up media, usually inferior to and lower in cost than the primary link, but adequate enough to be used for a short period of time until the primary communications link is repaired. Sometimes a manual change is needed to unplug the primary port and replace it with the diverse or back-up media choice.

- 10. Coverage Requirements:** In prior years, coverage requirements were more tied to mobile radio voice system deployments. Now, requirements are tied to programs and used to define, for example, the number of homes reached with an AMI system or for a load control program, or the number of feeder devices reached with a given technology. Usually a coverage requirement is used as part of a formal RFP bidding process, with the co-op providing the latitude and longitude coordinates of the sites that need to be reached and other attributes, such as antenna height.
- 11. Monitoring or Control Applications:** A monitoring application is a site such as a voltage regulator or fault indicator, where analog or status messages are gathered. A control application is a site, such as a feeder switch, that can be remotely opened or closed over the communications link. A site that provides monitoring functions only can most often get by with a slightly less reliable or less robust communications link compared to a site that provides control functions, which require the communications system to be available at any time it is needed.
- 12. Who (or What) Is Waiting for the Data:** There are various applications from which a human located in a dispatch center or service center is waiting to get a response on a given data interrogation of a meter, RTU, modem, or other devices to which the communications link is routed. For some applications, such as AMI, a human generally is not waiting for hourly meter reads to be delivered; rather, those data simply feed into a database. However, when a message is sent to a particular meter to identify a possible outage, a human generally is waiting. This concern relates back to the latency requirement discussed earlier. Therefore, a program like AMI would have several requirements tied to latency, with different requirements for different types of functionality (i.e., longer latency allowable for hourly meter reads versus shorter latency allowable for user-operated meter inquiries).
- 13. Direction—One-Way, Two-Way, Peer-to-Peer:** Most new communications media selections provide two-way communications. Some of the older paging and PLC technologies sent information only one way, but two-way technologies can both send and receive data. Peer-to-peer communications link two devices that are typically on feeders, such as relays. Some peer-to-peer applications will have extremely stringent latency requirements, such as 2 ms, and some as relaxed as 3 seconds.
- 14. Circuit-Switched Packet-Switched TDM:** Time Division Multiplexing (TDM) is a process of transferring signals over a single communications channel in such a way that, although they appear to be traveling at the same time, they actually are taking turns on time-slot-based sub-channels. TDM typically delivers latency of less than 4 ms and is extremely consistent in its transmission. TDM has been used heavily for the transport of analog phone systems, analog LMR, and relay protection in a peer-to-peer mode. It is used when a latency requirement is very stringent. More recently, most of the microwave products now provide several radio ports that can be configured in TDM mode, along with an Ethernet port that can transport packed data.
- 15. Jitter:** With many co-ops now routing VoIP traffic between their offices over an Ethernet link, as well as the increasing use of video transport, the impact of jitter has become important to understand. “Jitter” can be used to describe undesired timing fluctuations in a transmitted signal and an IP network. Jitter can result in incorrect decoding; dropping of packets, which may cause poor voice quality; pixelated video; and other errors. Jitter can occur for a number of reasons, including the way routers and switches queue packets, networks that have multiple routes from one node to another, non-uniform implementation of Quality of Service (QoS) rules, and just plain congestion. Jitter buffers can compensate

for jitter of up to about 100 ms, but excessive jitter (generally more than 100 ms) can result in dropped packets and will often increase end-to-end total latency. Many communication products include such jitter buffers, which can help. Depending on the codec and the compression standard used, 100 ms of delay mitigate jitter about the maximum target before it will begin impacting the audio quality.

Jitter is not very easy to test. Various standards establish protocols to allow VoIP to operate. Q931 protocols control call setup. H-225 defined protocols (RTCP) exchange information about lost packets end to end. ITU G113 includes specifications for transmission and processing impairments due to IP transport. VoIP and TDM over IP and video over IP are evolving over time. The standards controlling them and the test equipment designed to test them also are evolving.

In summary, the key aspects to consider when selecting the communications media for VoIP and video include the amount of latency expected between the two points and the associated hardware, software, and protocols, as described above, being used to mitigate the impact of jitter.

3.3 Typical Communications Infrastructure Requirements

The typical communications requirements shown in Table 1 all depend on the application, but some generalities do apply across applications and cooperative sizes. These requirements are presented as an overview and are not all-inclusive. Because these requirements are generalized, caution is advised when adopting those listed in this article for the purposes of procurement. Terrain, operational preferences, budget, master system software capabilities, density of devices, and various other factors will always influence the unique set of requirements a utility develops for each application. Each of the applications is discussed in more detail following **Table 1**.

Table 1. Typical Communications Infrastructure Requirements

#	Application	Typical File Size per Session – Bits	Typical Latency Required or Desired	Reliability Target	Preference for Private versus Commercial	How Frequently Are Data Typically Sent?
1	Backhaul of PLC-Based AMI from Substations	1,000 meters / substation 1,000,000 bits	60 seconds	99.9%	Private	Once per day to 4 times per day, depending on vendor
2	Backhaul of Fixed Wireless-Based AMI from Collector Locations	1,000 meters / collector 1,000,000 bits	15 to 30 seconds	99.9%	Private	Every 15 minutes to hourly
3	Modern Distribution SCADA	4,080 bits for DNP3 over IP	150 ms	99.99%	Private	Every 2 to 5 seconds
4	Feeder Distribution Automation: Control Applications	4,080 bits for DNP3 over IP	1 second	99.9%	Private	Every 5 to 10 seconds
	Feeder Distribution Automation: Monitoring Applications	4,080 bits for DNP3 over IP	5 seconds	99.9%	Commercial	Every 10 to 60 seconds
5	Direct Transfer Trip Distribution Relay Protection	800 to 2,400 bits	Must be < 2 seconds to as fast as 3 ms	99.99%	Private	By exception
6	Mobile Workforce Management (MWM)	1,000 to 10,000	10 seconds	99.9%	Commercial	Once every 5 to 15 minutes
7	VoIP across a Private Network	Assume about 80 kbps of TCP/IP bandwidth for each simultaneous call.				

- 1. Backhaul of PLC-Based AMI from Substations:** How often the data are sent from the substation PLC injector over the communications link to the co-op must be identified. This could range from every 5 minutes to once per day to once per week. A general rule of thumb is that a single meter read represents about 50 to 100 bytes of data (varying by vendor) when adding together the raw data and TCP/IP overheads. Therefore, the number of meters is a key variable in determining the size of the data file. Also, the AMI system will be used for a variety of ad-hoc requests, such as individual meter re-reads, outage detection and restoration reads, load control events, pre-pay meter reads, and voltage reads. As mentioned earlier, the expectation for the time it takes to retrieve the information is generally quicker for an ad-hoc read than for the daily meter read poll.
- 2. Backhaul of Fixed Wireless-Based AMI from Collector Locations:** One of the main benefits of fixed wireless AMI is the capability to bring fresh metering data from the meter to the AMI master more quickly over the AMI network and the ability of the system to sense meter outages and send a response to the master without having to poll the meter location. Most utilities are bringing fixed wireless AMI data from the collectors to the master each hour, but they bring metering data back more frequently for some customer groups, such as time-of-use customers, pre-pay customers, and Distributed Generation (DG) metering locations.
- 3. Modern Distribution SCADA:** Sometimes referred to as substation automation or modernization, this broad term refers to the often gradually upgraded electronic equipment in the substation, which primarily includes intelligent devices that are remotely accessible, provide two-way data flow with reliable communications, and are highly redundant. They also provide control of circuit breakers as well as alarming functionality, and act as a data historian and enable programs such as an integrated volt/VAR.

As an example, communications architecture within the substation is depicted in **Figure 2**. Also shown is the way in which downline DA is routed to a substation over a wireless facility to reach the Ethernet switch located in the substation, and the way in which AMI PLC data are routed through the same Ethernet switch to reach a higher speed communications link at the substation.

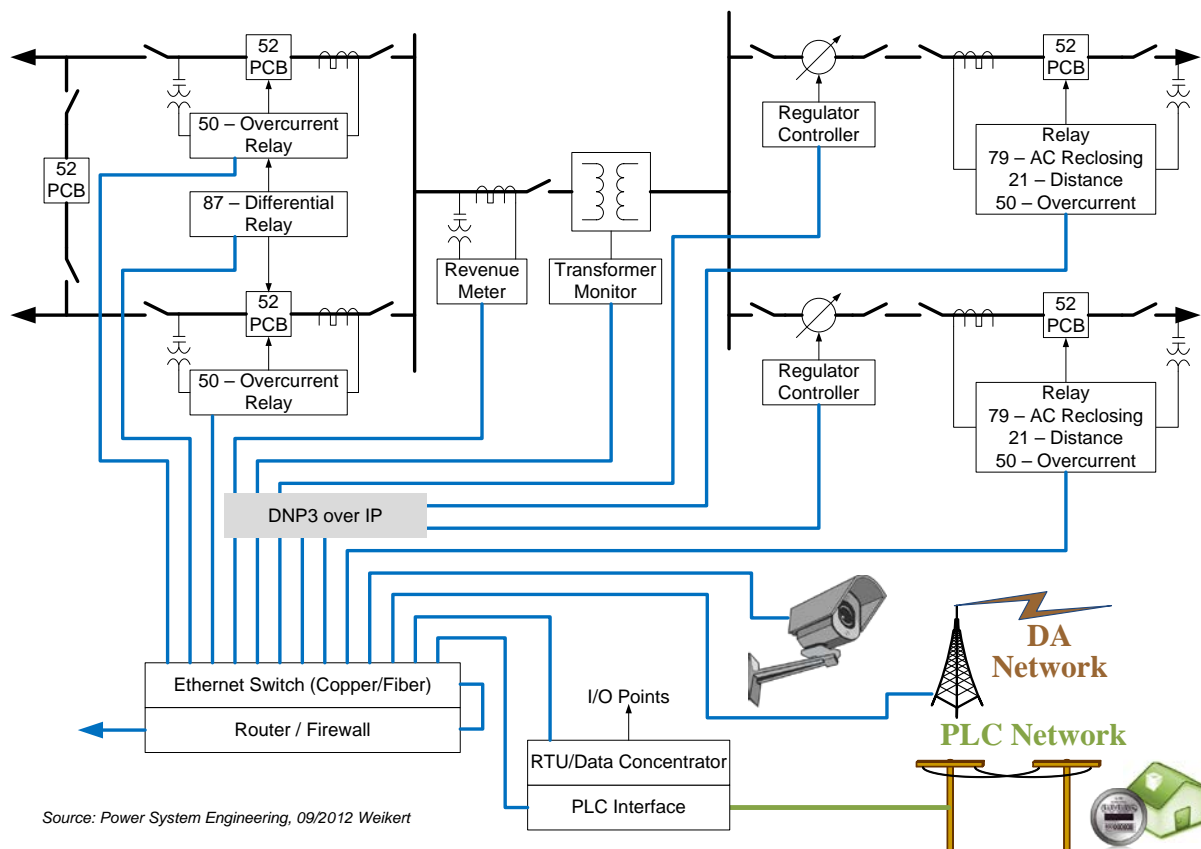

Source: Power System Engineering, 09/2012 Weikert

Figure 2. Communications Architecture within a Substation

4. Feeder Distribution Automation Control and Monitoring Applications: This generic term refers to a variety of distribution feeder programs. Nearly all DA programs include two-way communications between the feeder device and the SCADA master. For a few DA programs, such as a Direct Transfer Trip (DTT) scheme, the communications flow in a peer-to-peer mode between two feeder relays, with at least one of the connections routed to the feeder’s substation to update the RTU for any change in state.

The biggest challenge for any type of DA program generally is related to obtaining coverage to the antennas, usually located below the power lines, often 18–23 feet off the ground. Achieving the bandwidth requirement is not as significant a challenge. Most co-ops deploying DA have longer-term plans to communicate with several dozen DA points, often within the same area, so this is where the 10-year communications plan is particularly important in ensuring that the selected communications technologies are properly scalable.

Several *Tech Surveillance* articles recently focused on some of the most common DA programs: smart feeder switching, CVR, and Volt/VAR. **Table 2** indicates benefits for common DA programs.

Table 2. Benefits for Common Distribution Automation Programs

DA Program Types	Improved Reliability	Improved Performance Indices	Increased Profit & Reduced Costs	Reduce Losses	Improved Asset Life
Smart Switching	✓	✓	✓		✓
Conservation Voltage Reduction (CVR)			✓		
Power Factor Improvement (VAr)	✓	✓	✓	✓	✓
Fault Indicators	✓	✓	✓	✓	✓

5. **Direct Transfer Trip Distribution Relay Protection DA:** DTT schemes are starting to be deployed, as many co-ops are now deploying some type of DG program. A DTT scheme typically involves communications between three points: the DG source, a relay located at the point of interface, and a second relay located upstream close to the serving substation. Communications between the relays is peer to peer. The SCADA system at the serving substation can update the SCADA master with any state change of the relay.
6. **Mobile Workforce Management (MWM):** In prior years, MWM was defined primarily as the process in which service orders and work orders were routed from a special software program interfacing with a CIS, skinning down the data size to about 1,000 bytes, and then routing those data from the MWM server to a laptop located in a vehicle. With the introduction of tablet computers, smart phones, iPads, and the ease of video over smart phones and iPads, the applications for mobile computing are changing rapidly. Just a few years ago, a 4,800 bps mobile data network was adequate for most MWM programs, but now more robust mobile data communications are needed. There are only a few mobile data technologies that can deliver mobile broadband: 802.16e WiMax, some of the mesh technologies, white-space frequency, and cellular. Co-ops also can build hotspots with Wi-Fi and develop practices in which trucks visit hotspots for the transport of larger data files.
7. **VoIP across a Private Network:** VoIP comes into play for co-ops that have multiple offices sharing the same VoIP phone system. This means that the offices are connected with data lines and the branch offices are actually connected to the main office where the phone system server resides. In past years, co-ops used TDM to transport voice traffic, especially those using circuit-switched PBX phone systems, data lines ordered through a telephone company, or microwave or fiber links provided by the co-op through private communications. Now, with a VoIP phone system, the backhaul links used to connect the district office phone system to the primary office can use the same types of data lines used to transport Internet traffic or data from the CIS, SCADA, OMS, and other systems with native TCP/IP.

3.4 How Much Throughput Is Needed?

While the need for speed is obvious, determining data throughput and latency requirements can seem complicated. Determining the bandwidth requirements for a given application is often a two-step process. First, define the bandwidth and latency expectations to a given application device or location. For example, if the requirement is that the SCADA program deliver data in 1 second from a substation RTU to the SCADA master, then this is the defined latency that would be required of the system and measured during the system acceptance testing. After the bandwidth and latency requirements are defined, consider the planned network topology to assess the impact of network collisions.

For example, will several applications be routed to a common tower site that could act as a network node, or to another common network node? What applications may be selected for the use of commercial technologies versus private technologies owned by the co-op? **Figure 3** depicts a tower site being used as a major communications node.

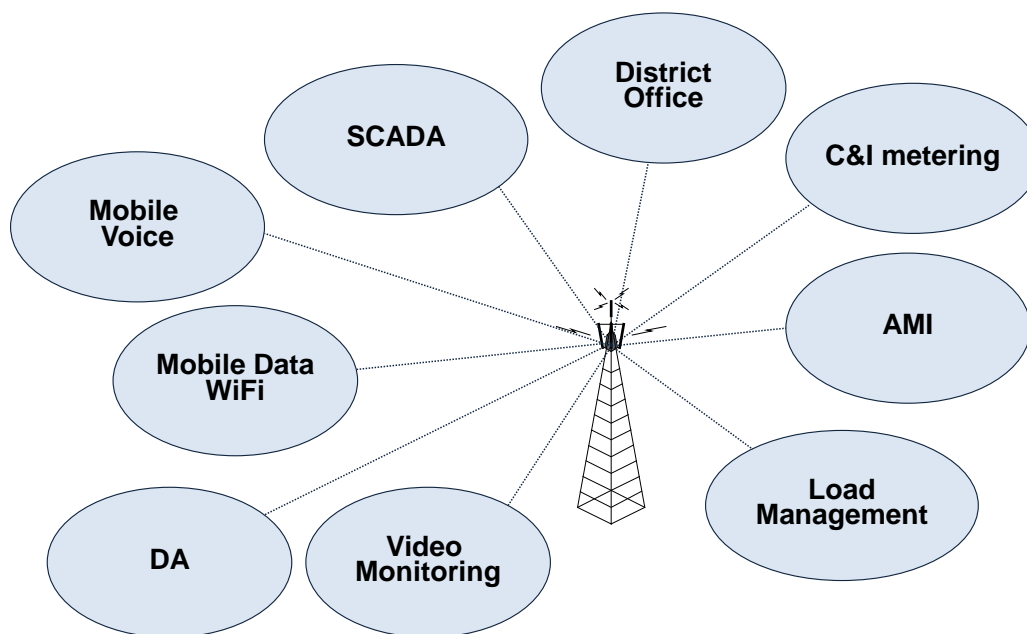

Figure 3. Tower Site as Communications Mode

The network topology illustrated in **Figure 3** requires that assumptions be made regarding each of the applications that flow into the common tower site. For example, how many meters are consolidated at a given collector or substation location? How many load control customers exist, and how often will the data be sent? What is the data acquisition means for SCADA or DA—polling, unsolicited report by exception, or shotgun polling? How many bytes are consumed by each application, and how frequently will those data come back from each application? This is why it is so important to plan the deployment timeline by application, including the number of devices and, if possible, their locations, over a period of 10 years to ensure the scalability of the selected communications technology.

Once a utility has compiled a list of the applications it will be including in the analysis, the next step is to determine the throughput requirements for each application. To determine the requirement for DA, for example, the amount of data per message (ranging from less than 100 bytes to multiple kilobytes), scan rates, requirements for round-trip latency, and device density all must be measured.

Note that devices such as RTUs, switches, capacitor bank controllers, and voltage regulators may be polled cyclically, with polling cycles (scan rates) that vary depending on the type of message and its priority. When DA device polling is unsolicited report-by-exception (RBX), throughput requirements during normal operations are significantly reduced versus throughput requirements during cyclic polling. In this case, bandwidth sizing is instead accomplished by determining the probable number of devices that will communicate through backhaul nodes during an outage, demand response, or other event. As the devices on an affected feeder may report exceptions in rapid succession, the ability to handle message collisions is important, particularly for slower

communications technologies. Also, the number of DA points that feed into a common DA master will impact the bandwidth requirements.

Figure 4 depicts a scenario in which field DA points feed into tower sites and substation DA collection nodes.

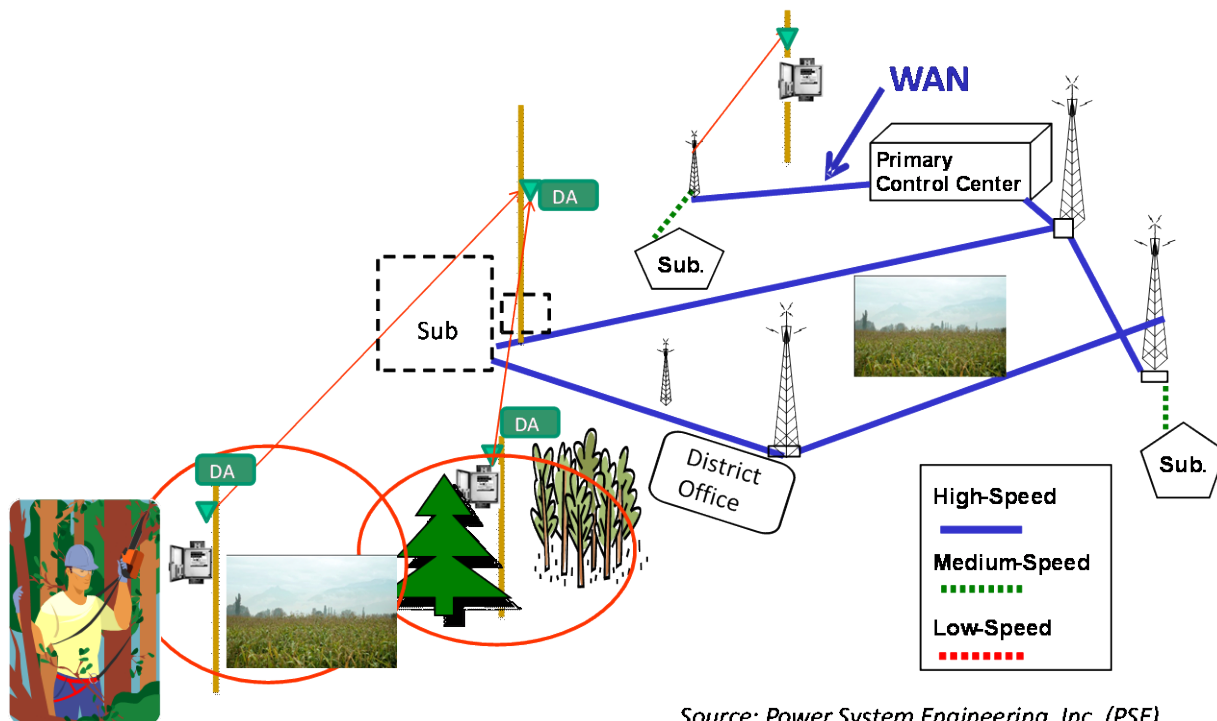

Source: Power System Engineering, Inc. (PSE)

Figure 4. DA Points Feeding into Tower Sites and Substation DA Collection Nodes

Similar throughput analysis should be completed for AMI, SCADA, mobile workforce, video security, and any other applications on a co-op’s list. The throughput for each application then is aggregated to determine the overall throughput and latency requirements for each backhaul node. The results may be verified by field and lab testing for existing and future applications.

Table 3 presents some of the typical requirements for common applications.

Table 3. Throughput Requirements for Common Applications

#	Applications	Bytes Per Remote Device Per Transaction (network overheads included)	Frequency of Transaction	Quantity of Devices Routing to Master Collection Site	Quantity of Bits Per Transaction	Typical Latency Required	Throughput Required at a Node Location
1	AMI: Single Meter Read	75	Every 15 minutes	1,000, varies by density	1,020,000	10 seconds	102 kbps
2	AMI: Single Meter Read	75	Once per hour	1,000	2,400,000	15 seconds	68 kbps
3	AMI: Single Meter Read	75	Once per hour	1,000	2,400,000	30 seconds	34 kbps
4	AMI: Outage Read	75	Sporadic	200	15,000	5 seconds	40 kbps
5	SCADA: Poll	300	Every 5 seconds	6 substations	248,480	1 second	24 kbps

#	Applications	Bytes Per Remote Device Per Transaction (network overheads included)	Frequency of Transaction	Quantity of Devices Routing to Master Collection Site	Quantity of Bits Per Transaction	Typical Latency Required	Throughput Required at a Node Location
6	DA (Collector Location)	100	Every 10 seconds	20 DA points to a single master	27,200	4 seconds	7 kbps
7	DA (Collection Location)	500	Every 10 seconds	20 DA points to a single master	136,000	4 seconds	34 kbps
8	Mobile Service Order	2,000	4 orders per transaction	NA	108,800	5 seconds	12.8 kbps
9	Video Monitoring	100,000	Per event	1	1,360,000	5 seconds	272 kbps

In summary, bandwidth requirements vary greatly based on the operational procedures established, the data acquisition interval, the architecture, and, in some cases, the vendor. Several variables can occur, for example, if any type of communication interruption occurs, such as if a given AMI or SCADA vendor’s master system errors out, thus causing reads to be missed. The challenge for substations where AMI, SCADA, direct connect to IEDs, and even DA is routed from downline locations to a substation, lies in estimating how often and how much data will be sent at the same time.

For locations where multiple applications are routed over the same communications link, it is common to create routing priorities and guidelines for an Ethernet switch to follow. For example, if multiple applications can be routed over the same link, a co-op might prioritize at least 50 kbps of the available pipe to SCADA. The next 100 kbps might be prioritized for AMI, and the lowest priority could be all the other applications, such as downline DA, MWM, video, etc.

3.4.1 Radio Frequency Bandwidth Data Rates: Vendor Quoted vs. Actual Installed

For wireless technologies, understanding the difference between the vendor-quoted radio frequency (RF) data rate (the vendor’s “marketing” specifications) and actual data throughput is crucial in determining whether a wireless technology will meet a co-op’s throughput and latency requirements. For example, a product with a stated data rate of 100 kbps may yield only 20 or 50 kbps of actual installed data throughput, due to such factors as hardware and software delays, RF packet overhead, communications protocol overhead, half-duplex data transmission, network contention, retries, and many other factors.

It is recommended to test the throughput of the technologies being considered, both in a controlled lab environment and in the field, using planned antennas, antenna height, etc. Front-end processors (FEPs) may be used to help lower-capacity technologies manage rapid polling or numerous unsolicited messages during events.

3.5 Summary

Cooperatives understand that the ramifications are too significant simply to take a guess at communications requirements. It all starts with creating a 10-year plan for the applications that require communications and that the co-op expects to add or enhance. The following then should be undertaken:

- ◆ Create an application-level roadmap by year. Ask questions such as: When will SCADA be upgraded? When and how will advanced DA be deployed? When will a new LMR system be added? When will the existing one-way load control program be retired? When will the existing AMI system be retired and replaced with a new technology? When will mobile service orders be added?
- ◆ Define the actual requirements for each application. Defining the number of bytes to be sent, the frequency with which data are to be sent, and the requirements for bandwidth and latency is a great start toward narrowing down communications infrastructure alternatives.
- ◆ Create a communications architecture plan that defines throughput at remotes and any network concentration points, and determine if the architecture will have multiple tiers with different technology at different tiers, as well as the degree of commercial versus private technology.
- ◆ Create a communications deployment build-out schedule.
- ◆ Develop a plan for staffing and support during and after deployment, and develop a project management plan for the deployment.
- ◆ Seek funding approvals from a management team, board, and other funding sources such as the Rural Utilities Service (RUS).
- ◆ Begin detailed design tasks and procurement.

SECTION 4: FUTURE WORK NEEDED ON TELECOMMUNICATIONS

By Maurice Martin, NRECA

Defining communications requirements is an important step, but only takes us so far. The communications problem still needs to be addressed on three levels: support from both federal and state regulators, technical innovation, and decision-making guidance.

4.1 Support from Regulators

The regulatory landscape is varied for co-ops. In some states, electric co-ops are barred from providing broadband services to customers. This prohibition may be a function of cable and telecommunications providers desiring to limit the field of those who offer service. There also may be other historical reasons for the prohibition. For example, there may be concerns about cross-subsidization of broadband services by electric customers. Nevertheless, the prohibition can be a problem if no other service provider is willing to fill the gap. In many rural areas, customers are limited to telecommunications technology that is not capable of handling the large amounts of data available today. The large incumbent telecommunications providers are not willing to serve areas where the economics of sparse population do not drive sufficient return on capital invested. Thus, very rural areas lack access to broadband. Increasingly, lack of broadband is a major disincentive to economic growth and investment—and businesses of all types and sizes only will grow more dependent on high-speed connections in the future.

In general, electric cooperatives are not trying to get into the telecommunication business. However, some electric cooperatives are exploring offering broadband services to their member customers in light of lack of service from any other provider. This exploration is consistent with Cooperative Principle #7—Concern for Community. That principle states, “While focusing on member needs, cooperatives work for the sustainable development of their communities (emphasis added) through policies accepted by their members.” In addition, if electric cooperatives had the option to sell their excess bandwidth (as Washington-St. Tammany is considering), they would have a funding mechanism for deploying the kind of high-speed telecommunication infrastructure needed to support their Smart Grid functions. Regulations that prohibit electric co-ops from offering broadband can thus have the unintended consequence of stopping grid modernization and stifling economic growth—a bleak scenario for rural America.

To offer broadband service to members, electric cooperatives must apply to the FCC to become Eligible Telecommunications Carriers (ETC). The designation as an ETC carries with it build-out milestones and deadlines as well as administrative reporting. While some electric cooperatives are electing to apply to become ETCs, others have chosen not to pursue that path.

Finally, many in the industry have articulated a need to dedicate a specific swath of spectrum to electric utilities as critical infrastructure providers. NRECA participates with other CII industry groups in exploring the possibility of dedicated spectrum for co-op needs. Spectrum is a scarce good with a high value, and many groups and industries are competing to buy it.

4.2 Technical Innovation

As stated, utilities have a number of technologies to choose from when upgrading their telecommunications, but each technology has its strengths and weaknesses; none by itself is a “one size fits all” solution. Co-ops must contend with varying topographies, customer densities, grid topographies, and other variables—in some cases, none of the existent technologies offers an affordable solution.

There are fascinating new technologies under development that may close the gap. Virginia Tech is working on cognitive radio networks—a communication system that is aware of its environment and adapts its performance accordingly. The “cognitive engine” is able to adjust operating frequency, protocol, and waveform, and monitors its own performance continuously. Cognitive radio holds out the promise of more efficient use of the spectrum, as well as more automation in deploying and maintaining a wireless infrastructure. The latter has particular value for rural cooperatives, many of which have limited staff expertise in communications. (Note in the case studies those co-ops that chose their systems based on staff familiarity with the equipment or manufacturer. A more automated system of deployment and maintenance would make new technology more accessible.)

The communications field is rich with ideas and innovation. While this gives co-ops more choices, it also increases the complexity of decision making when it becomes time for a communications upgrade. As seen from the case studies of co-ops that upgraded their communications, when faced with an overwhelmingly complex choice, staff sometimes will simplify by choosing technology with which they are already familiar.

4.3 Decision-Making Guidance

A guide for analyzing options for a communications upgrade would be a tremendous boon for both short- and long-term decision making. Such a guide would take into account communications systems currently deployed, the current and future needs of the utility, topology and customer density, and other important factors. It would identify logical phases for building out a communications infrastructure and take into account anticipated advances in communications.

The creation of such a guide is an ambitious project, but NRECA has found a partner to help with this effort: power and automation technology maker ABB. The company is currently in an information-gathering mode, meeting with co-ops and discussing their communication needs, goals, and challenges. The guide produced will be “vendor agnostic”—that is, it will not favor any one manufacturer. ABB’s interest is in seeing more deployment of high-speed communications, which will open up new markets for its equipment sales.

NRECA and ABB expect the guide to be completed in 2014 and they will publish it for the entire co-op community. This effort will build on lessons learned from the Smart Grid Demonstration Project and point the way to a more advanced, fully functional Smart Grid of the future.